



Type: _____

Product Ordering Guide

Sample

TB2 - DM-35U
1 2 3 4 5



1. Base Model

TB

2. Length & Wattage

- 2 2' 10w
- 4 4' 20w

3. Dimming

0-10V (12%-100%)

4. CCT

- 30 3000K
- 35 3500K
- 40 4000K
- 50 5000K

5. Grid Type

- F 9/16" Flat
- S 9/16" Slot
- I 9/16" Interlude
- U 15/16" Flat

Optional Ordering Guide

Optional

- Emergency
- CCEA
- 24VDC

Interactive Menu

Order Information	Page 1
Product Specification	Page 2
Mounting	Page 3
Dimension	Page 4
Photometric Data - 9/16" Flat	Page 5
Photometric Data - 9/16" Slot	Page 6
Photometric Data - 15/16" Flat	Page 7

TB SERIES

Architectural LED Luminaire

Product Specification

Specification

9/16" Flat

9/16" Slot

9/16" Interlude

15/16" Flat



Model No.	TB-DM -XXF	TB-DM-XXS	TB-DM-XXI	TB-DM-XXU
Lengths Wattages Lumen	2ft 10w 1150lm 4ft 20w 2300lm	2ft 10w 1150lm 4ft 20w 2300lm	2ft 10w 1150lm 4ft 20w 2300lm	2ft 10w 1300lm 4ft 20w 2600lm
Efficacy	115 lm/w	115 lm/w	115 lm/w	130 lm/w
120° Beam Angle	✓	✓	✓	✓
100-277VAC Input	✓	✓	✓	✓
24V DC Option	✓	✓		✓
Custom Pattern	✓	✓		✓
Plenum Rated Cable Option	✓	✓	✓	✓
Emergency Option	✓	✓	✓	✓
CCEA Option	✓			✓
UL/CUL	✓	✓	✓	✓
DLC	✓			✓

Product Performance

Optics

Unique design with triple sides allows the light to diffuse for a direct and indirect lighting combination with 120° beam angle.

Electrical

LED Driver It can be parallel connected up to 6' (2' fixture) and 12' (4' fixture) max per power supply. Max distance from fixtures to power supply is 8 feet with 24 AWG wire with RJ45 terminal, which makes easy installation and safe wiring.

THD <20%

Power Factor >0.9

Input Voltage Standard electronic drivers are cULus recognized and available for 100-277V AC or 24VDC.

Optional Function

Emergency Option Optional low voltage 100-277V emergency LED driver for lighting up to 120 minutes in event of power failure, that meets critical life-safety lighting requirements.

Warranty

5-year limited warranty on LED and driver.

LED System

CRI	Minimum 80 color rendering index
CCT	3000K, 3500K, 4000K and 5000K with a great color consistency
LED	life Minimum 50,000h with 87.8% of lumen maintenance in 25° ambient temperature, in compliance with IES LM-80 testing measurements.
Thermal Management	Aluminum housing acting as the heat sink to maximize life.

Mounting

It is a lighting solution that can be replaced with 9/16" and 15/16" removable cross tee of the grid ceiling, allowing our linear light to be seamlessly integrated into the suspended ceiling.

Approvals

- US Patent (10125934)
- cULus listed for damp locations
- Tested to IESNA LM-79 and LM-80
- DesignLights Consortium Qualified and classified for DLC standard, refer to www.designlights.org for details
- CCEA listed
- IC Rated

T-grids Ceiling Compatibility

9/16" Flat

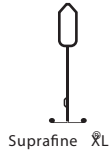

9/16" Slot



9/16" Interlude

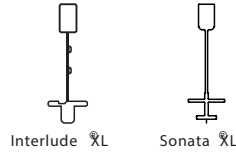

15/16" Flat

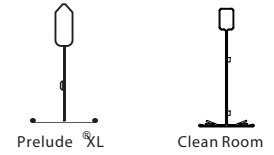

Custom Pattern



T-Grid LED can be installed in many configurations by replacing any of the cross tees between the main runners of the grid ceiling assembly.

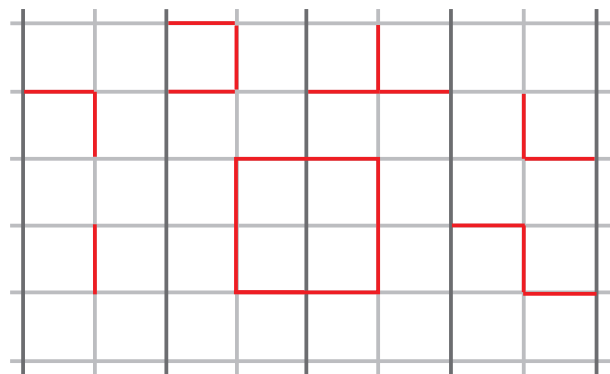

- Examples of configurations
- Possible positions for T-grid LED light modules
- One-piece main runner cannot be replaced

It is free to create compelling spaces, and your space no longer has to be restricted to a single pattern on the ceiling. Custom pattern such as "L", "T", "+", "□" etc.

Custom Pattern Version

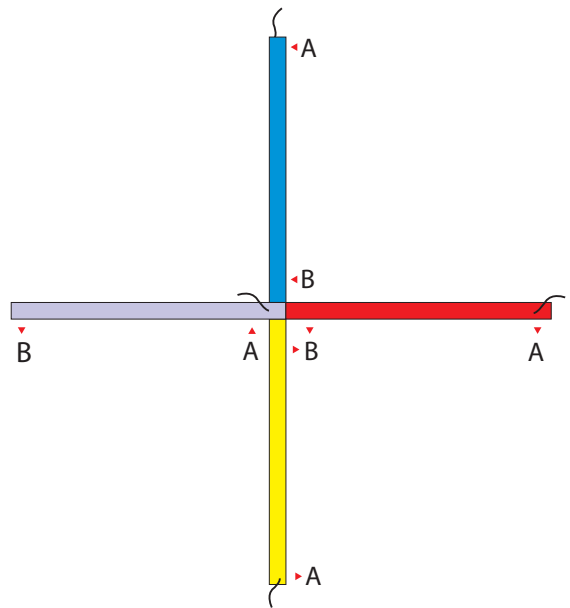
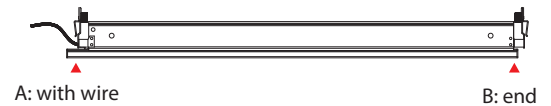

Remark: Only one A-end with wire in joint

TB SERIES

Architectural LED Luminaire

Dimension

Dimension

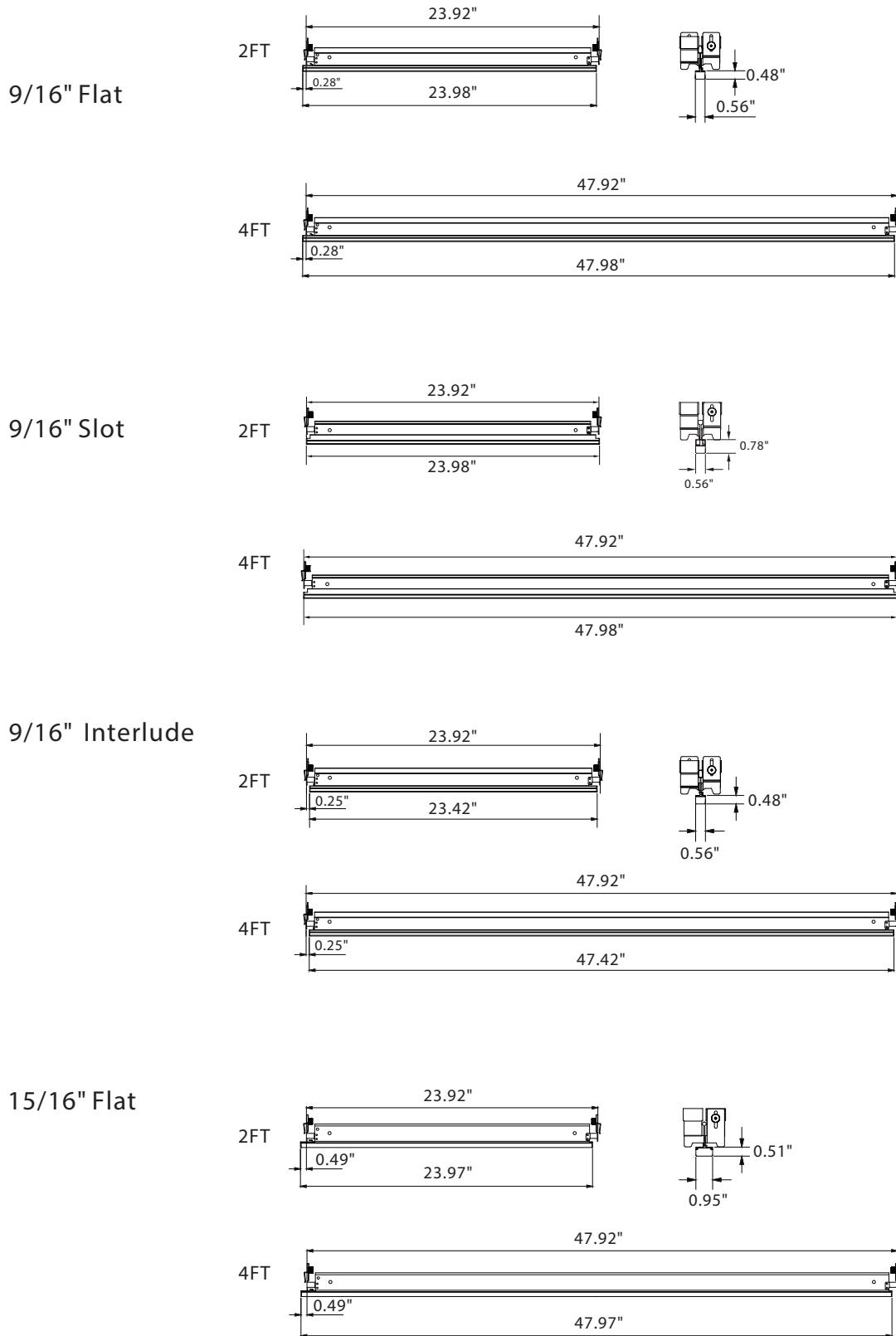

TB SERIES

Architectural LED Luminaire

9/16" Flat

Photometry

Fixture photometry has been conducted accredited testing laboratory in accordance with IESNA LM-79-08. IESNA LM-79-08 specifies the entire luminaire as the source resulting in a fixture efficiency of 100%. Result may vary per actual order.

Luminous Intensity Distribution Diagram

TB2-DM-XXF (Flat)

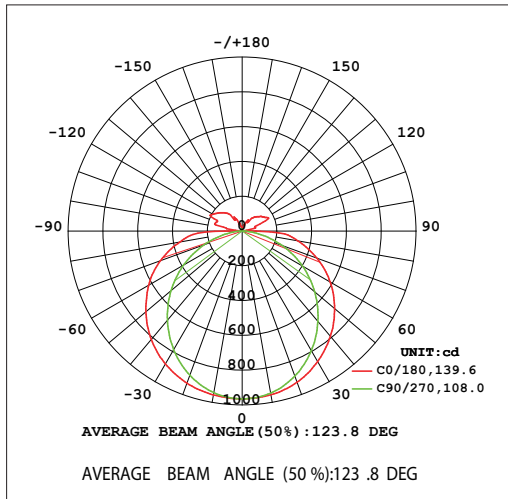

Average Illuminance Curve

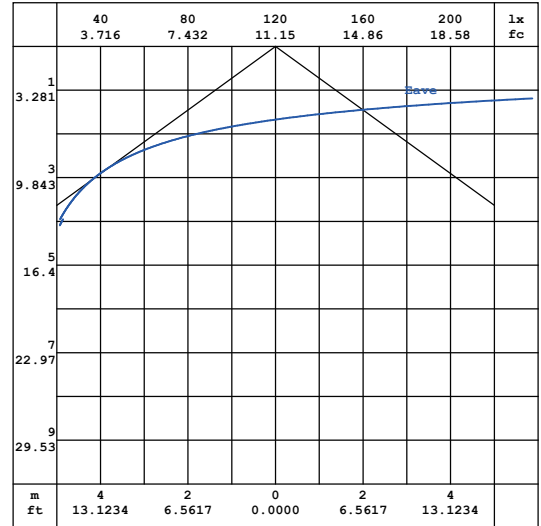

Note: The Curves indicate the illuminated area and the average illumination when the luminaire is at different distance

Zonal Flux Diagram

T	C0	C45	C90	C135	C180	C225	C270	C315
10	955.6	950.8	945.9	951.0	956.1	948.8	943.3	949.6
20	924.4	910.7	887.0	913.1	930.1	909.9	881.5	905.9
30	867.6	839.9	795.0	848.5	882.2	842.3	788.0	835.1
40	789.3	746.1	678.0	758.4	813.4	751.4	669.0	739.3
50	693.1	635.1	545.0	653.8	722.6	645.8	534.3	628.6
60	583.9	512.6	399.3	535.0	620.3	527.7	387.9	505.8
70	458.0	379.2	245.9	405.5	500.9	397.5	234.7	373.2
80	324.6	242.7	96.57	269.6	364.7	262.4	87.41	239.3
90	80.83	70.90	4.782	90.84	103.1	71.82	4.927	67.25

DEG LUMINOUS INTENSITY:cd

Zonal Lumen Summary

T	φzone	φtotal	%lum , lamp
0-10	91.38	91.38	2.5,2.5
10-20	263.4	354.8	9.72,9.72
20-30	403.8	758.5	20.8,20.8
30-40	496.0	1255	34.4,34.4
40-50	532.2	1787	49,49
50-60	511.9	2299	63,63
60-70	439.6	2738	75.1,75.1
70-80	324.00	3062	83.9,83.9
80-90	60.91	991.3	89,89

UNIT :lm

Coefficients Of Utilization

ppc	80%		70%		50%		30%		10%		0					
pw	50%	30%	10%	50%	30%	10%	50%	30%	10%	50%	30%	10%	0			
pf	20%		20%		20%		20%		20%		0					
RCR	RCR:Room Cavity Ratio			(CU)												
0.0	116	116	116	112	112	112	105	105	105	98	98	98	92	92	92	89
1.0	99	94	89	95	91	87	89	85	82	83	80	78	78	76	73	70
2.0	85	77	71	82	75	69	77	71	66	72	67	63	67	63	60	57
3.0	74	65	58	72	63	57	67	60	55	63	57	52	59	54	50	47
4.0	65	56	49	63	54	48	59	52	46	55	49	44	52	47	42	40
5.0	58	49	42	56	47	41	53	45	39	50	43	38	47	41	37	34
6.0	52	43	36	50	42	35	47	40	34	45	38	33	42	36	32	30
7.0	47	38	32	46	37	31	43	36	30	41	34	29	38	33	28	26
8.0	43	34	28	42	33	28	39	32	27	37	31	26	35	29	25	23
9.0	39	31	25	38	30	25	36	29	24	34	28	23	32	27	23	21
10.0	36	28	23	35	27	22	33	26	22	32	25	21	30	25	20	19

TB SERIES

Architectural LED Luminaire

9/16" Slot

Photometry

Fixture photometry has been conducted accredited testing laboratory in accordance with IESNA LM-79-08. IESNA LM-79-08 specifies the entire luminaire as the source resulting in a fixture efficiency of 100%. Result may vary per actual order.

Luminous Intensity Distribution Diagram

TB2-DM-XXS

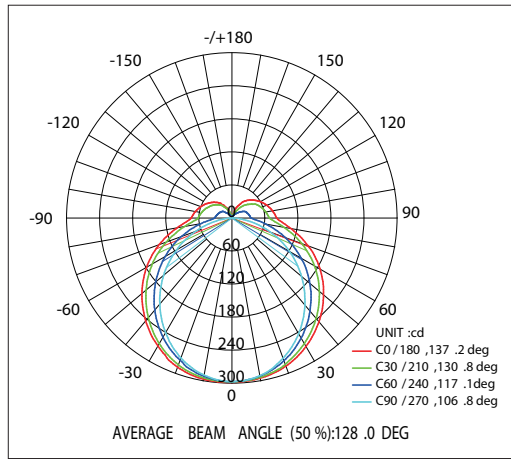

Average Illuminance Curve

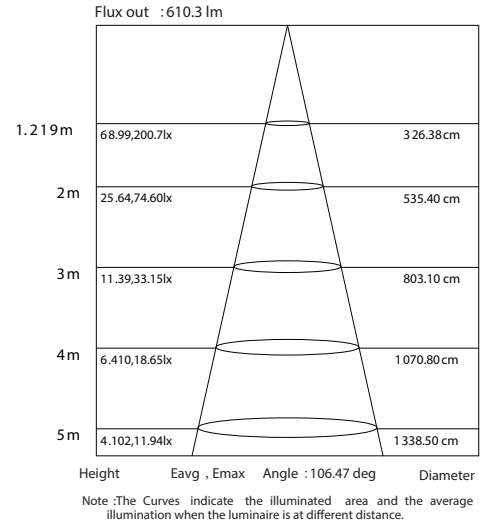

Zonal Flux Diagram

T	C0	C45	C90	C135	C180	C225	C270	C315
10	295.2	292.6	290.7	293.3	297.1	293.3	289.8	291.5
20	286.2	279.0	271.0	280.0	288.2	279.9	270.3	277.1
30	269.2	258.0	242.3	258.0	268.8	257.4	240.8	255.3
40	245.7	230.0	206.2	228.6	243.6	227.7	203.8	226.8
50	217.4	197.1	165.0	193.9	213.5	192.9	162.2	193.4
60	184.6	160.2	120.7	155.5	178.9	154.1	116.3	155.9
70	147.0	120.1	74.5	114.2	140.2	112.6	69.35	115.5
80	108.2	79.96	29.44	73.39	100.4	72.28	24.87	75.81
90	81.66	53.09	0.0606	46.95	74.29	48.08	0.0211	48.83
DEG	LUMINOUS INTENSITY:cd							

Zonal Lumen Summary

T	φzone	φtotal	%lum , lamp
0-10	28.15	28.15	2.4,0.42
10-20	81.06	109.2	9.3,1.63
20-30	123.8	233.0	19.8,3.47
30-40	151.5	384.5	32.7,5.73
40-50	162.0	546.5	46.5,8.15
50-60	155.1	701.6	59.7,10.5
60-70	132.0	833.6	79.2,13.9
70-80	96.80	930.4	84.4,14.8
80-90	60.91	991.3	88.4,15.5
	UNIT :lm		

Coefficients Of Utilization

ppc	80%			70%			50%			30%			0			
pw	50%	30%	10%	50%	30%	10%	50%	30%	10%	50%	30%	10%	10%	0		
pfc	20%			20%			20%			20%			0			
RCR	RCR :Room Cavity Ratio			(CU)												
0.0	20	20	20	19	19	19	18	18	18	17	17	17	15	15	15	15
1.0	17	16	15	16	16	15	15	15	14	14	14	13	13	13	12	12
2.0	15	13	12	14	13	12	13	12	11	12	11	11	11	11	10	9
3.0	13	11	10	12	11	10	11	10	9	11	10	9	10	9	8	8
4.0	11	10	8	11	9	8	10	9	8	9	8	7	9	8	7	7
5.0	10	8	7	10	8	7	9	8	7	8	7	6	8	7	6	6
6.0	9	7	6	9	7	6	8	7	6	8	6	5	7	5	5	5
7.0	8	7	6	8	6	5	7	6	5	7	6	5	6	5	5	4
8.0	7	6	5	7	6	5	7	5	5	6	5	4	6	5	4	4
9.0	7	5	4	7	5	4	6	5	4	6	5	4	5	4	4	3
10.0	6	5	4	6	5	4	6	5	4	5	4	4	5	4	3	3

TB SERIES

Architectural LED Luminaire

15/16" Flat

Photometry

Fixture photometry has been conducted accredited testing laboratory in accordance with IESNA LM-79-08. IESNA LM-79-08 specifies the entire luminaire as the source resulting in a fixture efficiency of 100%. Result may vary per actual order.

Luminous Intensity Distribution Diagram

TB2-DM-XXU

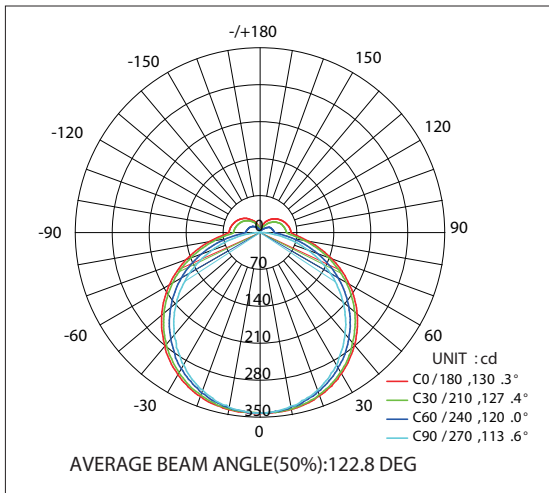

Average Illuminance Curve

Flux out : 765.9 lm

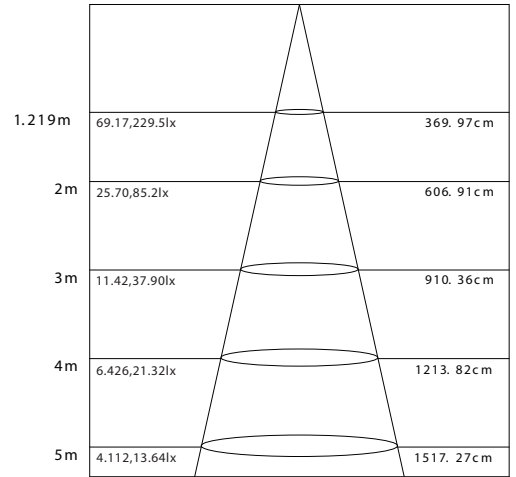

Note :The Curves indicate the illuminated area and the average illumination when the luminaire is at different distance

Zonal Flux Diagram

T	C0	C45	C90	C135	C180	C225	C270	C315
10	340.3	337.3	334.0	337.2	341.2	338.4	336.3	338.8
20	329.2	324.4	317.8	325.0	330.3	326.2	318.1	325.3
30	308.7	301.0	290.3	302.5	311.7	303.5	290.0	302.8
40	278.2	268.4	250.9	269.5	281.1	270.2	252.8	269.6
50	240.1	227.6	205.6	229.0	243.5	230.2	206.5	229.6
60	194.5	180.3	153.2	182.8	198.7	182.8	154.6	182.4
70	143.7	127.4	96.49	130.0	148.6	129.9	96.09	128.9
80	91.91	73.78	38.68	76.83	96.57	76.27	38.26	74.64
90	59.16	40.08	3.115	41.60	59.70	40.68	3.064	40.96

DEG LUMINOUS INTENSITY:cd

Zonal Lumen Summary

T	φzone	φtotal	%lum , lamp
0-10	32.45	32.45	2.5,2.47
10-20	93.95	126.4	9.74,9.61
20-30	144.8	271.2	20.9,20.6
30-40	178.8	450.0	34.7,34.2
40-50	191.6	641.7	49.4,48.8
50-60	182.3	823.9	63.5,62.6
60-70	151.4	975.3	75.1,74.1
70-80	103.9	1079	83.1,82
80-90	55.27	1134	87.4,86.2

UNIT :lm

Coefficients Of Utilization

ppc	80%			70%			50%			30%			0		
pw	50%	30%	10%	50%	30%	10%	50%	30%	10%	50%	30%	10%	0		
pfc	20%			20%			20%			20%			0		
RCR	RCR :Room Cavity Ratio			(CU)											
0.0	115	115	115	110	110	110	103	103	103	96	96	96	89	89	86
1.0	98	93	89	94	90	86	88	84	81	82	79	77	76	74	69
2.0	84	77	71	81	75	69	76	70	66	71	66	62	66	62	56
3.0	74	65	58	71	63	57	66	60	54	62	56	52	58	53	47
4.0	65	56	49	63	54	48	59	52	46	55	49	44	51	46	39
5.0	58	49	42	56	47	41	52	45	39	49	43	38	46	41	34
6.0	52	43	36	50	42	36	47	40	34	44	38	33	41	36	29
7.0	47	38	32	45	37	31	43	35	30	40	34	29	38	32	26
8.0	42	34	28	41	33	28	39	32	27	37	30	26	35	29	23
9.0	39	31	25	38	30	25	36	29	24	34	28	23	32	26	21
10.0	36	28	23	35	27	22	33	26	22	31	25	21	30	24	19