

ANCHORAGE DETAIL

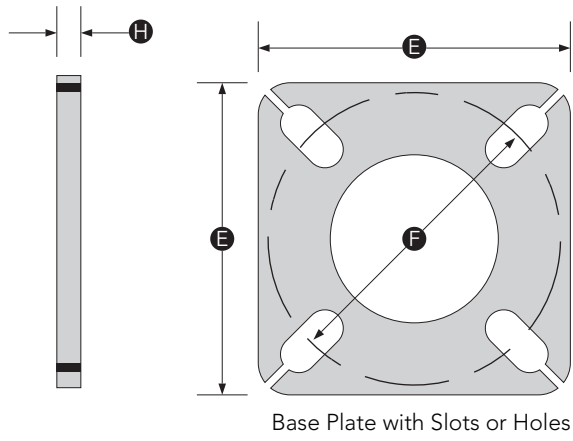

Anchor Base size	Wall thick H	Base Plate Square E	Bolt Circle Range (in)	Bolt Circle F	Bolt Projection
4"	0.75"	10.5"	8-11	9.5"	3.5"
5"	0.75"	11"	10.6-12	11.3"	3.5"

DIMENSIONS

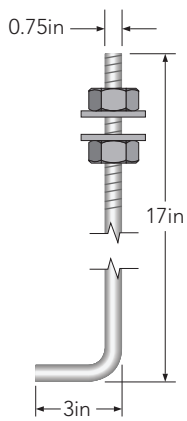
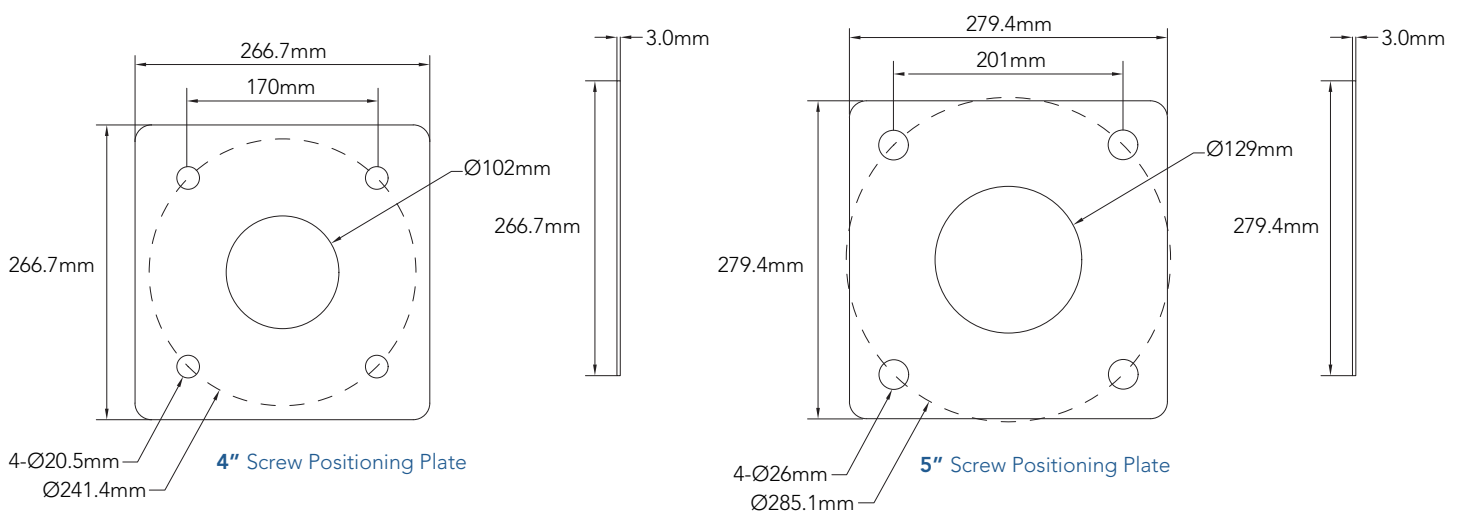

A1 Anchor Bolt
Suit for 10ft, 15ft, 20ft, 25ft

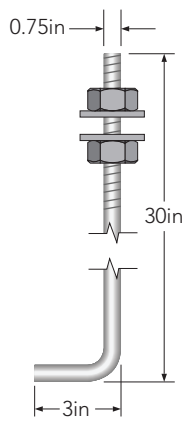

A2 Anchor Bolt
Suit for 30ft

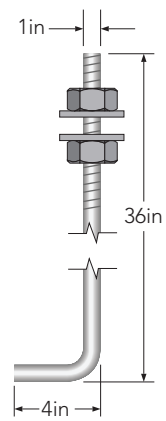

A3 Anchor Bolt